

Lecture Note
On
Power Station Engineering
6th Semester

By

Prof. Jayanti M. Sahoo



Department of Mechanical Engineering
Raajdhani Engineering College

INTRODUCTION

A power plant can be considered as a machinery set up that produces and delivers a flow of mechanical or electrical energy. Generators are considered as the main equipment for the electric power generation. It generates electricity when it is driven by a prime mover. On the basis of the types of prime movers used, power plants are classified.

The major power plants are,

- Steam power plant
- Diesel power plant
- Gas turbine power plant
- Nuclear power plant
- Hydroelectric power plant

Sources of Energy:

Energy sources are classified as:

- Conventional Energy Sources or Non-Renewable Energy Sources
- Non-conventional Energy Sources or Renewable Energy Sources

Conventional Energy Sources:

These sources are finite and exhaustible. Once consumed, these sources cannot be replaced. Examples of these sources are energy from Coal, timber, petroleum, lignite, natural gas, fossil fuels, nuclear fuels etc.

Non-conventional Energy Sources:

These sources are continuous and non-exhaustible. Examples of these sources are geothermal energy, wind energy, tidal energy, nuclear fusion, bio-energy, solar energy etc. These sources give energy continuously without depletion.

Captive power stations:

An electricity generation station which is used by an industrial or commercial energy consumer for its own energy consumption is known as a Captive power station. Captive power plants can exchange their surplus energy with the grid.

Central stations:

An electricity generation station which is not made for the self uses of the industries is known as a Central power station. It generates more power than the captive power plant. It is suitable for large scale power generation. These stations are located outside of the end users and connected to a high voltage transmission network. The electricity generated from these stations are purchased by the consumers.

Classification of Power Plants:

Conventional Power Plants	Non-Conventional Power Plant
<ul style="list-style-type: none"> ➤ Steam/Thermal Power Plants ➤ Diesel Power Plants ➤ Gas Turbine Power Plants ➤ Hydro-Electric Power Plants ➤ Nuclear Power Plants 	<ul style="list-style-type: none"> ➤ Solar base power plant ➤ Wind Energy Power Plant ➤ Geothermal Energy ➤ Tidal Wave Energy Power Plant ➤ Ocean Thermal energy conversion Plant ➤ Biogas, Biomass Energy Power Plant ➤ Thermoelectric Generator

Importance of Electrical Power:

The importance of electricity now day is many more than our imagination. In every field there is necessity of electricity. The importance of electric power can be understood from its wide area of application. Some of the most notable uses of electricity are: Entertainment, Healthcare, Engineering, Transport and Communication, Outdoors, Household, Commercial, Office, Fuel and Space etc.

Overview of Method of Electrical Power Generation:

The various sources which are used to generate electric power are discussed below.

Steam Power:

- Steam power plants known as Coal-fired power plants use steam as a source to generate electricity. But the flue gas emitted by the plant to the atmosphere possesses harmful gases and therefore it is not environment friendly.
- **But it is now a major electricity generating plant.**

Hydro Power:

- The gravitational force of flowing water is utilized in hydro power plants to run the turbines. In these plants, water is forced to possess kinetic and pressure energy which is converted into mechanical energy on the rotation of runner of the hydraulic turbine.
- **It is a clean and renewable resource of from which electricity is obtained.**
- As compared to fossil fuel-powered energy plants, hydroelectric power plants emit fewer greenhouse gases.
- **The construction of hydroelectric power plants and dams requires huge investment.**

Nuclear Power:

- Nuclear power plants generate a high amount of electricity from a nuclear fission reaction using uranium as fuel.
- Nuclear power plants require low quantities of fuel but produce a large amount of power. Once started, it run efficiently.
- **It is more reliable compared to renewable sources of energy such as solar and wind.**
- In these plants, water is converted into steam after receiving heat energy from the nuclear reaction and this steam is used in the turbine for energy conversion.

Diesel engine power:

- **This is used for small-scale production of electric power by using diesel as fuel.**
- **Diesel is a non-renewable source of energy which makes these plants non-durable.**
- They are installed in places where there is no easy availability of alternative power sources and are mainly used as a backup for uninterrupted power supply whenever there are outages.
- **It is considered as unsuitable for high maintenance costs and diesel prices.**

Wind Power:

- Wind turbines capture kinetic energy from wind and convert it into electricity. The amount of energy depends on speed of the wind.
- **It is a renewable source of energy.**
- Wind power projects typically require huge capital expenditure. After the wind turbines are built, operational costs involved in maintaining wind power plants are low and they are generally considered to be relatively cost-effective.

Solar Power:

- Solar energy plants convert energy from the sun into thermal or electrical energy. It gives the renewable energy sources.
- They do not require high maintenance and last for about 20 to 25 years but requires high initial cost for installation.

Tidal Power:

- Tidal energy is generated from converting energy from the force tides into power. This power is created when tides rotate submerged turbines.
- Its production is considered more predictable compared to wind energy and solar power.
- **Tidal power is still not widely used.**

Biomass:

- Burning organic materials produces high pressure gas that can drive a turbine-generator to make electricity.

Geothermal energy:

- Geothermal power plants utilize the internal heat of earth's crust to heat water to produce steam. This steam gives energy to the turbine-generator to produce electricity.
- Geothermal power plants are considered to be environmentally friendly and emit lower levels of harmful gases compared with coal-fired power plants.

THERMAL POWER STATION

A thermal power station or a coal fired thermal power plant uses coal as the primary fuel. Heat released from the burning of coal is used to boil the water to make superheated steam for driving the steam turbine. It is the most conventional method of generating electric power with high efficiency.

Steam Power Plant Layout:

The different types of systems and components used in steam power plant are as follows:

- **Boiler**
- Turbine
- Condensers
 - Cooling tower
- Coal handling system
- Ash handling system
- Draught system
- Feed water treatment plant
- Pumping system
- Mountings like Safety valve, stop valve, pressure gauge and water gauge. ▪
- Accessories like Air preheater, economizer, super heater and feed heaters ▪
- Generator, Transformer and Electricity storage and distribution system

Layout of thermal plant can be easily understood by dividing the plant components into four circuits.

▪ Coal and ash circuit

Coal and Ash circuit in a thermal power plant layout mainly takes care of supplying the boiler with coal from the storage for combustion and collect the ash from the boiler. Coal storage, preparation and supply to the boiler mainly handled by the coal handling plant whereas the ash collection, storage and disposal mainly handled by the ash handling plant.

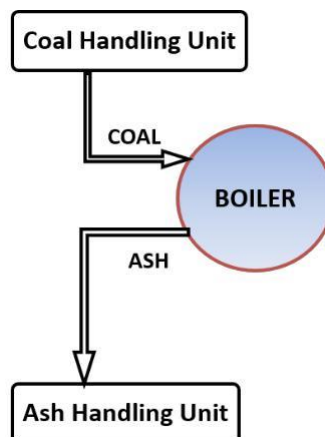

▪ Air and gas circuit

- Air and gas circuit in a thermal power plant layout mainly takes care of supplying preheated air obtained from the Air preheater to the furnace and releasing the exhaust gas from the furnace after the combustion of fuel.
- Atmospheric air is drawn into the Air preheater through the forced draught fan where air is heated by the hot flue gas coming out from the furnace.
- Flue gas having very high temperature is used in the super heater, economizer and air preheater where its heat is recovered. After that the flue gas is passes through the electrostatic precipitator for removing dust from the gas and then gas is drawn into the chimney by the induced draught fan to release the gas to atmosphere.

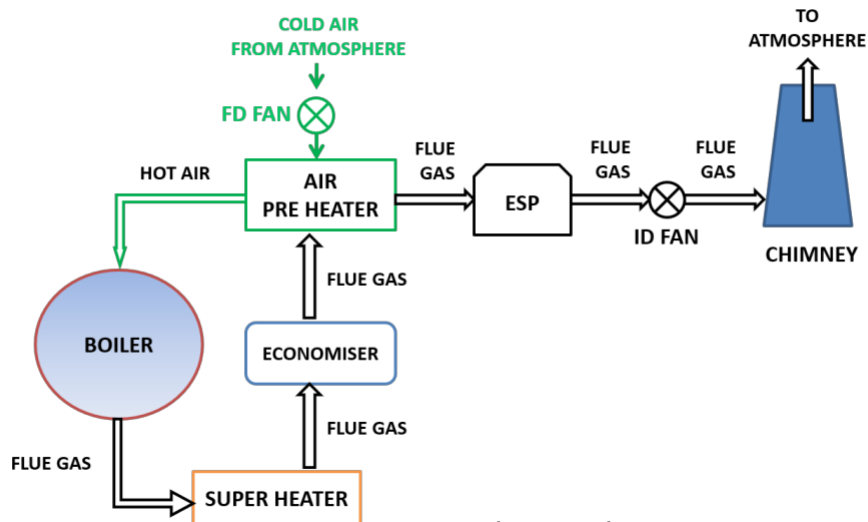

Feed water and steam circuit

- The water and steam circuit in a thermal power plant layout mainly takes care of feeding hot water obtained from the economizer to the boiler and supplying steam obtained from the boiler to the turbine to generate power.
- The steam that is expelled by the prime mover in the thermal power plant layout is then condensed in a condenser for re-use in the boiler. The condensed water is forced through a pump into the feed water heaters. Pre heated water is supplied into the boiler. To make up for the lost steam and water make up water is feed to the boiler.

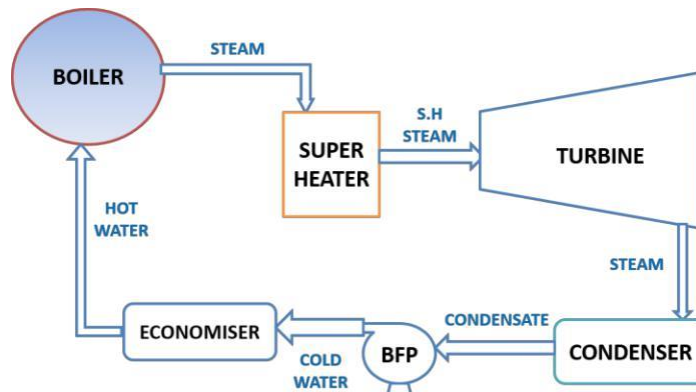

Cooling water circuit

- Cooling water is passed through the condenser where the steam is condensed. The water after being heated by steam is discharged to Cooling tower. Cooling water circuit can also be a closed system where the cooled water is sent through cooling towers for re-use in the power plant. The cooling water circulation in the condenser of a thermal power plant layout helps in maintaining a low pressure in the condenser.

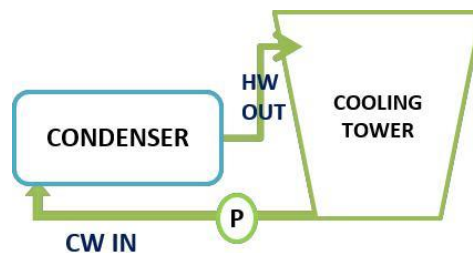

In a steam power plant, Steam is generated in a boiler, expanded in the prime mover and condensed in the condenser and fed into the boiler again. The layout of steam power plant is given below.

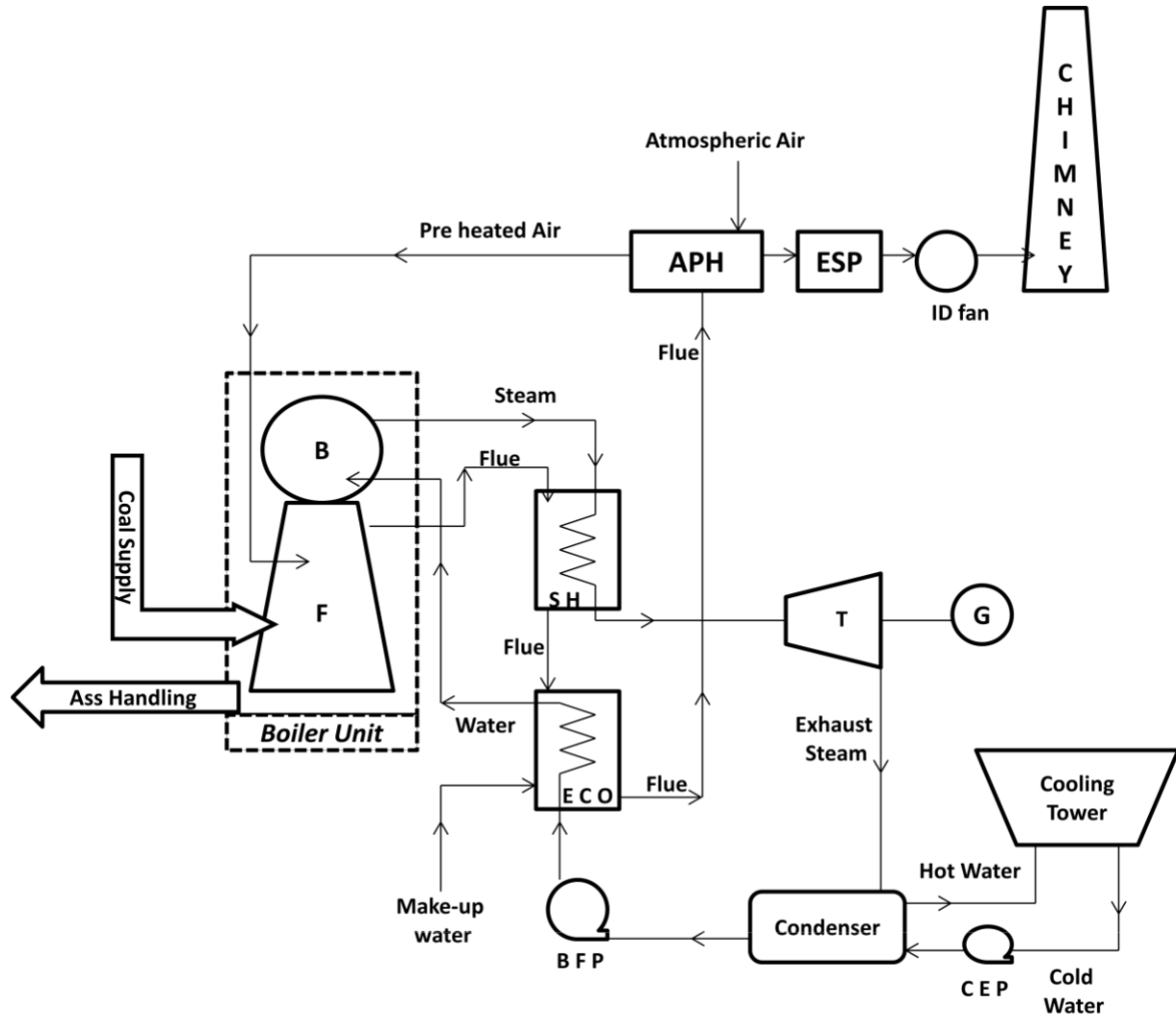

Carnot vapour power cycle:

The P-V and T-s diagram for Carnot vapor cycle is shown below.

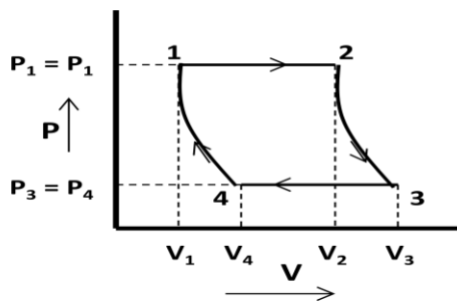

(P-V diagram)

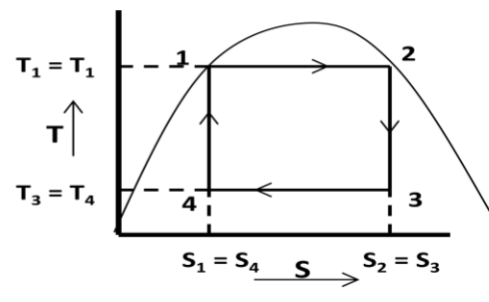

(T-s diagram)

Carnot vapor cycle consists of the four processes as described below.

• Isothermal expansion:

In figure process 1-2 shows the isothermal expansion process. In this process water gets heated in the boiler at constant temperature ($T_1 = T_2$) and pressure ($P_1 = P_2$) and gets converted into steam. Entropy increases from s_1 to s_2 and dry steam is collected at state 2. Heat absorbed by water ($Q_{1-2} = T_1 (s_2 - s_1)$)

- Reversible adiabatic expansion:**
 In figure process 2-3 shows the reversible adiabatic expansion process. In this process steam expands inside the turbine at constant entropy ($s_1 = s_2$) and produce shaft power. Steam becomes wet at state 3. Pressure and temperature get changed from state 2-3.
- Isothermal compression:**
 In figure process 3-4 shows the isothermal compression process. In this process steam gets condensed in the condenser at constant temperature ($T_3 = T_4$) and pressure ($P_3 = P_4$). Entropy decreases from s_3 to s_4 and wet steam is collected at state 3.
 Heat rejected from steam ($Q_{3-4} = T_3 (s_3 - s_4) = T_3 (s_2 - s_1)$)
- Reversible adiabatic compression:**
 In figure process 4-1 shows the reversible adiabatic compression process. In this process wet steam at state 4 gets compressed to state 1 at constant entropy ($s_4 = s_1$) in feed pump. Pressure and Temperature get changed from state 4-1.

Efficiency of Carnot Cycle:

$$\begin{aligned} \text{Efficiency} = \eta_{\text{Carnot}} &= \frac{\text{Workdone}}{\text{Heat Supplied}} = \frac{\text{Heat supplied} - \text{heat rejected}}{\text{Heat Supplied}} \\ &= \frac{Q_{1-2} - Q_{3-4}}{Q_{1-2}} = \frac{T_1(s_2 - s_1) - T_3(s_3 - s_2)}{T_1(s_2 - s_1)} = \frac{T_1 - T_3}{T_1} = 1 - \frac{T_3}{T_1} \end{aligned}$$

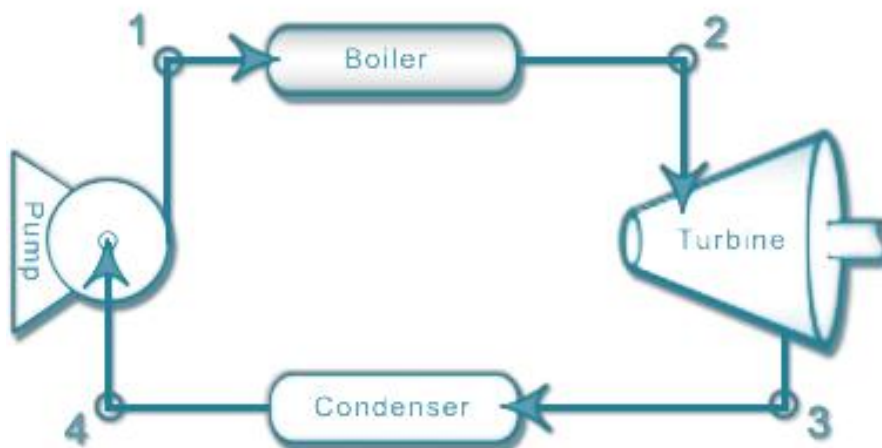

(Simple steam power plant working on Carnot cycle)

The limitations of Carnot vapor cycle are

- It is difficult to compress a wet vapor isentropically to the saturated state (process 4-1).
- It is difficult to control the quality of the condensate coming out of the condenser.
- The efficiency of the Carnot cycle is greatly affected by the temperature T_1 .
- The cycle is still more difficult to operate in practice with superheated steam.

Rankine cycle:

A steam power plant using steam as working substance works basically on Rankine cycle.

The T-S diagram for Rankine cycle is shown below.

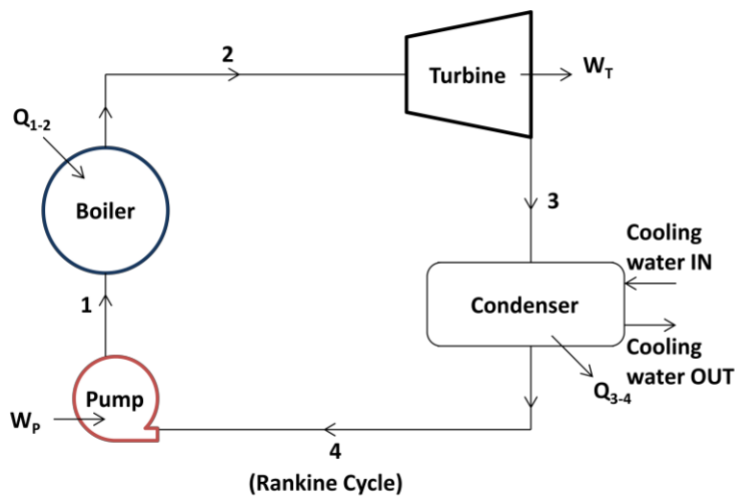

Rankine cycle consists of the four processes as described below.

• Isothermal expansion:

In figure process 1-2 shows the isothermal expansion process. In this process saturated water at state 1 is converted into dry saturated steam at state 2 in a steam boiler at constant pressure ($P_1 = P_2$). Water absorbs the latent heat of vaporization ($h_{fg1} = h_{fg2}$) and converted into dry saturated steam.

Amount of heat absorbed in process 1-2 = $h_{fg2} = h_2 - h_{f2}$ (for dry steam: $h_2 = h_{fg2} + h_{f2}$)

• Reversible adiabatic or Isentropic expansion process:

In figure process 2-3 shows the reversible adiabatic or isentropic expansion process. In this process dry saturated steam at state 2 expands isentropically in turbine to state 3. Steam at state 3 is wet.

Work done in the process 2-3 = Turbine work = $h_2 - h_3$

• Isothermal compression process:

In figure process 3-4 shows the isothermal compression process. In this process exhaust steam of turbine is cooled by cold water in the condenser at constant pressure ($P_3 = P_4$) and constant temperature ($T_3 = T_4$). Steam releases latent heat of vaporization and converted into saturated water.

Amount of heat rejected in process 3-4 = $h_{fg3} = h_3 - h_{f4}$

• Reversible adiabatic or Isentropic process:

In figure process 4-1 shows the reversible adiabatic or isentropic process. In this process saturated water is drawn by the pump and feed into the boiler.

Work done in this process 4-1 = Pump work = $h_1 - h_{f4}$

Efficiency of Rankine cycle:

$$\text{Efficiency} = \frac{\text{Net Workdone}}{\text{Heat Supplied}} = \frac{W - W_p}{Q_{1-2}} = \frac{(h_2 - h_3) - (h_1 - h_{f4})}{(h_2 - h_{f1})}$$

If pump work is neglected then $W_P = 0$

Various end conditions of steam:

The T-S diagram for various end conditions of steam can be discussed by the Rankine cycle.

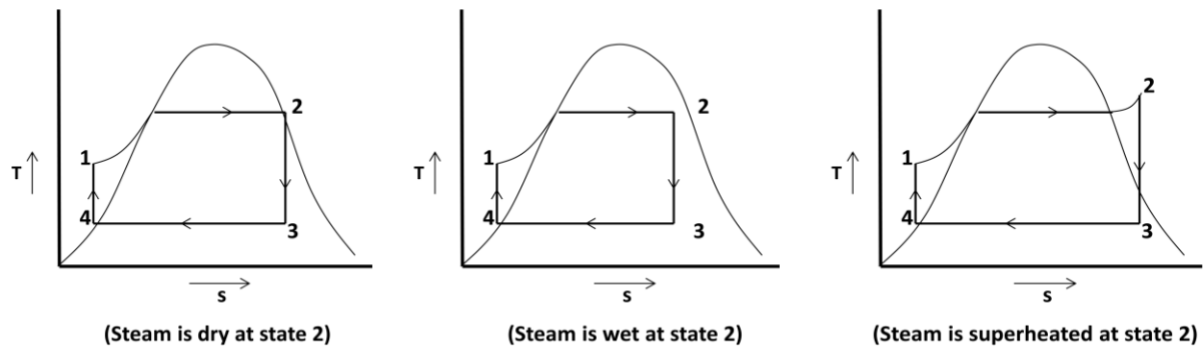

- Efficiency ratio:**
 It is the ratio of thermal efficiency to Rankine efficiency or actual cycle efficiency to ideal cycle efficiency.

$$\text{Efficiency ratio} = \frac{\text{Thermal efficiency}}{\text{Rankine efficiency}}$$

- Thermal efficiency:**

$$\text{Thermal efficiency} = \frac{3600 P}{m (h_2 - h_{f3})}$$

Where, P = power developed in kW and

m = mass of steam supplied

- Work ratio:**
 It is the ratio of net work done to the turbine work.

$$\text{Work ratio} = \frac{\text{Turbine work} - \text{Compressor work}}{\text{Turbine work}}$$

- Specific steam consumption:**
 It is defined as the mass of steam supplied to the turbine to develop unit power output. It is also known as steam rate or specific rate of flow of steam.

$$\text{Specific steam consumption} = \frac{3600}{h_2 - h_3} \text{ kg / kWh}$$

Problems:

- Q.1) In a steam power cycle, the steam supply is at 15 bar and dry and saturated. The condenser pressure is 0.4 bar. Calculate the Carnot and Rankine efficiencies of the cycle. Neglect pump work.
- Q.2) A simple Rankine cycle works between pressures 28 bar and 0.06 bar, the initial condition of steam being dry saturated. Calculate the cycle efficiency, work ratio and specific steam consumption.
- Q.3) A steam turbine receives steam at 15 bar and 350°C and exhausts to the condenser at 0.6 bar. For the ideal Rankine cycle operating between these two limits, determine the (i) heat supplied, (ii) heat rejected, (iii) net work done (iv) thermal efficiency.
- Q.4) Steam at 50 bar and 400°C expands in a Rankine cycle to 0.5 bar. For a mass flow rate of 150 kg/s of steam determine (i) power developed, (ii) thermal efficiency, (iii) specific steam consumption.
- Q.5) Dry and saturated steam at 15 bar is supplied to a steam turbine working in Rankine cycle. The exhaust takes place at 1 bar. Calculate (i) Rankine efficiency, (ii) steam consumption per kWh if the efficiency ratio is 0.65.
- Q.6) A turbine working on a Rankine cycle is supplied with dry saturated steam at 25 bar and exhaust takes place at 0.2 bar. For a steam flow rate of 10 kg/s, estimate – (i) quality of steam at the end of expansion, (ii) turbine shaft work, (iii) power required to drive the pump, (iv) work ratio, (v) Rankine efficiency, (vi) heat flow in condenser.

Boiler Accessories:

Boiler accessories are the set of devices that are used to increase the efficiency of the boiler. These devices improve the boiler operation.

The following are some of the accessories which are used in boiler.

· **Air pre heater:**

- It is a heat exchanger which converts the cold air into hot air from the heat exchange between atmospheric air and flue gas.
- It recovers heat from the flue gas coming out of the Economizer.
- It is installed between the economiser and the chimney.
- The air required for the purpose of combustion is drawn through the air preheater where its temperature is raised. It is then passed through ducts to the furnace.
- The preheated air gives higher furnace temperature which results in more heat transfer to the water and thus increases the evaporative capacity per kg of fuel. It increases the boiler efficiency.

· **Economizer:**

- It is a heat exchanger which converts the cold water into hot water from the heat exchange between feed water and flue gas.
- It recovers heat from the flue gas coming out of the superheater.
- It improves the economy of the steam boiler.

· **Super heater:**

- It is a heat exchanger which converts the steam coming from the boiler into superheated steam from the heat exchange between steam and flue gas.
- It recovers heat from the flue gas coming out of boiler.
- Its purpose is to increase the temperature of saturated steam without raising its pressure. It is generally an integral part of a boiler which is located in the path of hot flue gases from the furnace.

· **Electrostatic precipitator:**

- It uses electrostatic forces to separate dust particles from exhaust gases.
- The contaminated exhaust gas flow through the passage formed by a number of high-voltage, direct-current discharge electrodes and grounded collecting electrodes.
- The airborne particles receive negative charge while passing through the ionized field between the discharge and collecting electrodes.
- These charged particles get attracted towards the positively charged grounded or collecting electrode and adhere to it.
- The collected material on the collecting electrodes is removed by rapping or vibrating the collecting electrodes.

Need of boiler mountings:

Boiler mountings are the set of safety devices installed on the boiler for its safe operation. These are very essential for a boiler to operate it safely.

The following are some of the mountings which are used in boiler.

- **Pressure Gauge:** It is used to measure the pressure of steam inside the boiler.
- **Water level Indicator:** It is used to indicate the water level in the boiler.
- **Safety Valve:** It is used to blows off the excess steam when steam pressure reaches above safety level.
- **Steam Stop Valve:** It is used to stop the steam in the boiler and transfer steam when it is required.
- **Blow off Valve:** It is used to blow off the impurities or sediments settled down in the boiler.
- **Feed check Valve:** It is used to control the flow of water from feed pump to the boiler.

Operation of boiler:

- The boiler is a closed vessel. The basic function of boiler is to convert water into steam. Water is supplied into the boiler drum where it is heated by hot gases that are formed by burning fuel in the furnace. When the steam at required pressure is generated inside the boiler, the steam stop valve releases the steam. This steam is superheated in a superheater before it is supplied into the turbine.
- The various mountings and accessories of boiler helps to run the boiler safely and to improve plant efficiency respectively.

Draught systems:

- Boiler draught is the pressure difference between absolute gas pressure within a furnace or chimney and atmospheric pressure which causes the flow of gas.
- Draught can be obtained by the use of chimney, fan, steam or air jet or a combination of these. ▪ Boiler Draught provide an adequate supply of air for fuel combustion. It can throw out the exhaust gases of combustion from the combustion chamber. It can discharge flue gases to the atmosphere through the chimney.
- The draughts may be classified as Natural Draught and Artificial Draught.

Natural Draught:

- When the draught is produced with the help of chimney only, it is known as Natural Draught. ▪ Natural draught system employs a tall chimney and don't require any external power for producing draught.

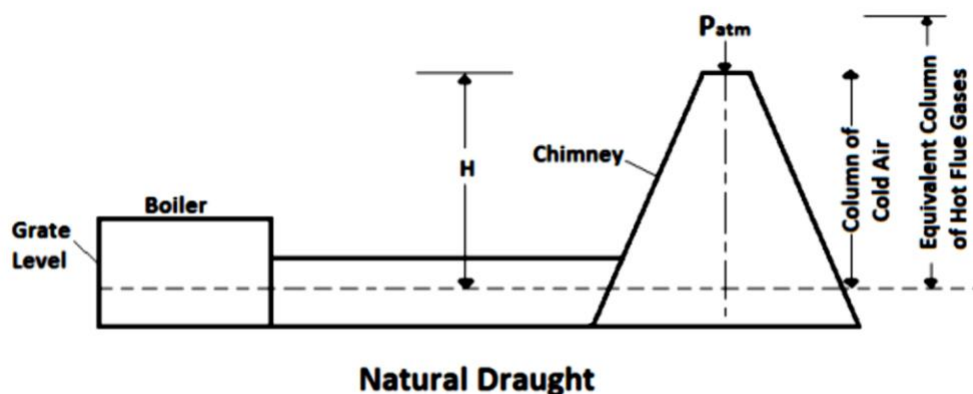

Advantages of Natural Draught

- It is produced with the help of chimney only. It does not require any external power for producing the draught.
- It has low capital and maintenance cost.
- Simple in design and construction.
- It has a long life. It leaves the flue gas at a high level.

Disadvantages of Natural Draught

- Maximum pressure available for producing draught by the chimney is less.
- The available draught decreased with increase in outside air temperature.
- Flue gases have to be discharged at high temperature which lowers the plant overall efficiency.

Artificial Draught:

- When the draught is produced by any other means except chimney it is known as Artificial Draught.
- To meet the high draught demand, artificial draught system is used which is classified as steam jet draught and mechanical draught.

Mechanical Draught:

- It is an artificial draught where draught is produced by the help of fans or blowers.
- It is more economical and its control is easy,
- It increases the rate of combustion by which low-grade fuel can also be used.
- It reduces fuel consumption and makes boiler operation cheaper.
- It can be classified as Forced draught, Induced draught and Balanced draught.

Forced draught:

- In this type of draught, a blower known as forced draught fan (FD fan) is placed before the grate. It forces the air into the grate through the closed ash pit. Air is forced to flow through the entire system under pressure.

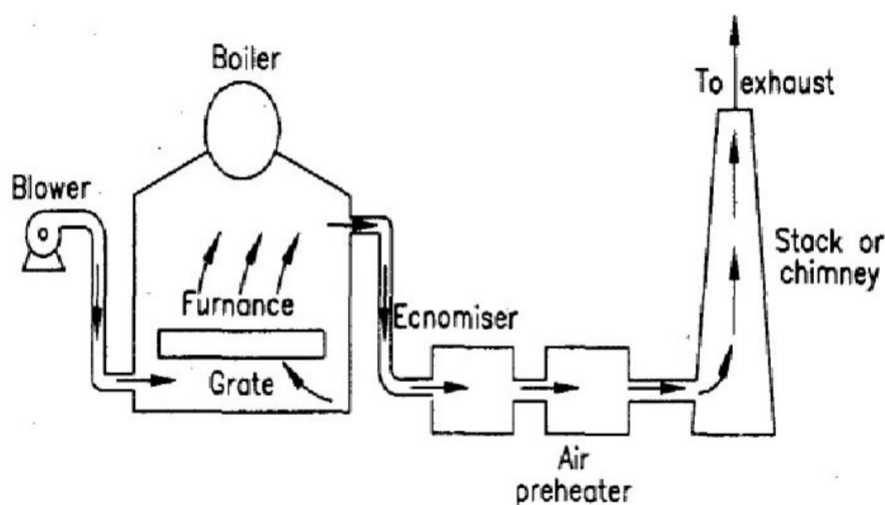

Induced draught:

- In this type of draught, a centrifugal fan known as induced draught fan (ID fan) is placed near the base of the chimney. The ID fan draws the furnace flue gas and forces the gas up through the chimney. Its action is similar to that of the natural draught.

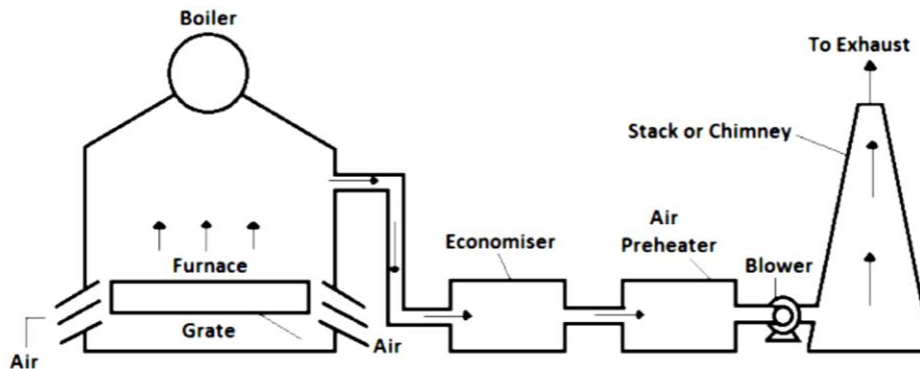
**Balanced draught:**

- Balanced draught is the combination of forced draught and induced draught.
- It overcomes the difficulties that are seen by using the forced draught or induced draught alone. It maintains the balance.
- The forced draught fan supplies the combustion air for better combustion of fuel and overcomes the resistance of fuel bed.
- The induced draught removes the flue gas and excess air from the furnace and helps to release it through chimney. It helps to maintain the pressure inside the furnace below atmospheric.
- If the forced draught is applied alone, there will be high pressure in the furnace. It causes difficulties in lightening and inspecting the boiler. There is possibility of blowing out of fire from the furnace which may disable the furnace work.
- If the induced draught is used alone, there will be difficulties in inspecting the boiler because cold air may rush into the furnace as the pressure inside the furnace is under atmospheric pressure.

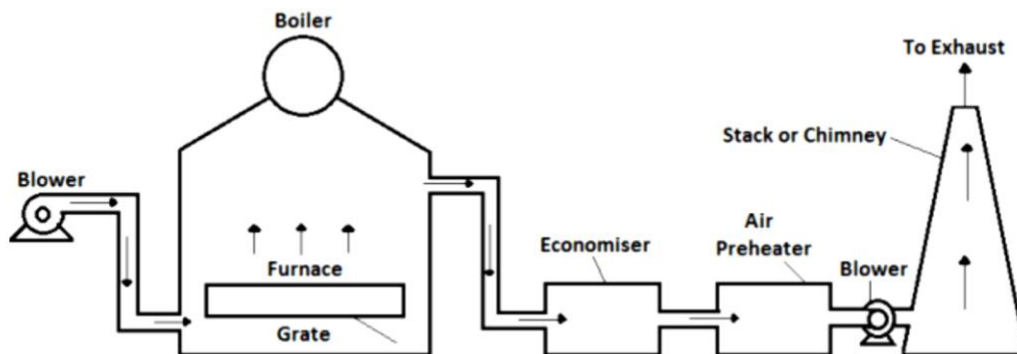
**Advantages of Artificial or Mechanical Draught**

- It increases the rate of combustion for which low-grade fuel can be used in the furnace. So, fuel cost is reduced.
- The desired value of draught can be produced, which is not obtained in natural draught.
- It reduces the smoke level and reduces the height of chimney.
- It is more economical and its control is easy.
- It saves the energy. It improves plant efficiency as maximum heat can be utilized.
- It reduces fuel consumption and makes boiler operation cheaper.

Disadvantages of Artificial or Mechanical Draught:

- **The initial cost is high.**
- The running cost is also high due to consumption of electricity but it is compensated by other savings.
- **Fans and blowers produce noise.**

Steam prime movers or Steam Turbine:

The steam turbine is used to convert the thermal energy of steam into mechanical energy by means of rotation of turbine shaft. This mechanical energy is used by generator to produce electrical energy.

The steam coming from the boiler rotates the turbine runner when strikes on it. Thus, mechanical energy is produced due to rotation of shaft of the turbine. When the turbine shaft rotates, the generator shaft coupled to the turbine shaft is also rotated.

Advantages of steam turbine:

- **It has higher thermal efficiency.**
- It can provide a good range of uniform brake horse power.
- It is properly balanced and so, vibration problem is minimised.
- It gives high rpm.
- It is reliable and durable.
- **It needs no lubrication.**

Disadvantages of steam turbine:

- It is less responsive to changes in power demand compared to reciprocating engines and gas turbines.
- It takes long start up time compared to reciprocating engines and gas turbines.
- It is less efficient at part load conditions than reciprocating engines and gas turbines.

Classification of steam turbine:

The steam turbines may be classified into the following types:

- **According to the mode of steam action**
 - Impulse turbine
 - Reaction turbine
- **According to the direction of steam flow**
 - Axial flow turbine
 - Radial flow turbine.
- **According to the exhaust condition of steam**
 - Condensing turbine
 - Non-considering turbine
- **According to the pressure of steam**
 - High pressure turbine
 - Medium pressure turbine
 - Low pressure turbine
- **According to the number of stages**
 - Single stage turbine
 - Multi stage turbine

Elements of steam turbine:

The components of steam turbine are

- **Steam Chest and Casing:**
 - The casing contains the rotor and nozzles through which the steam is expanded.
 - The steam chest is connected with the higher pressure and low-pressure steam lines.
 - The steam chest and casing protect the turbine from surrounding.
 - It encloses the steam inside the turbine.
- **Nozzles:**
 - These are used to increase the kinetic energy of steam.
- **Rotor:**
 - The rotor consists of disc mounted on a shaft. Number of blades are mounted on the periphery of the disc.
 - The shaft extends beyond the casing. One end of the shaft is connected with the governor and other end is coupled with the shaft of the generator.
 - The main function of the rotor is to convert the thermal energy of the incoming steam into kinetic energy.
- **Blades**
 - Number of blades mounted on the periphery of the disc are used to receive the steam on it. These are used for energy conversion and pressure and velocity variation.
- **Governor**
 - It is used to maintain the mean equilibrium speed of the steam turbine.

Difference between Impulse and reaction turbine:

Impulse turbine

1. The steam flows through the nozzles and impinges on the moving blades.
2. The steam impinges on the buckets with kinetic energy.
3. The steam may or may not be admitted over the whole circumference.
4. The steam pressure remains constant during its flow through the moving blades.
5. The negative velocity of steam while gliding over the blades remains constant.
6. The blades are symmetrical.
7. The number of stages required is less for the same power developed.

Reaction turbine

1. The steam flows first through guide mechanism and then through the moving blades.
2. The steam glides over the moving vanes with pressure and kinetic energy.
3. The steam must be admitted over the whole circumference.
4. The steam pressure is reduced during its flow through the moving blades.
5. The relative velocity of steam while gliding over the moving blades increase
6. The blades are not symmetrical
7. The number of stages required is more for the same power developed.

Governing of Steam turbine:

- The function of a governor is to control the fluctuation of speed of a steam turbine.
- When the steam turbine is connected to drive an alternator, there may be variation of load. According to the load on the alternator, turbine speed fluctuates. This fluctuation can be overcome by using a governing method.
- The different governing methods are:
 - Throttle governing
 - By-pass governing
 - Nozzle governing

Throttle Governing:

- This method is very simple and less costly. This is used to reduce inlet steam pressure by throttle valve operated by governing mechanism on part loads.
- An oil relay is used to operate the throttle valve.
- When the turbine works on less than full load condition, the load on the turbine suddenly released, governor speed increases with rotor speed and sleeve moves upward. So, relay piston under oil pressure moves downward and partially closes throttle valve. Then the sleeve comes to its position when equilibrium speed is obtained.

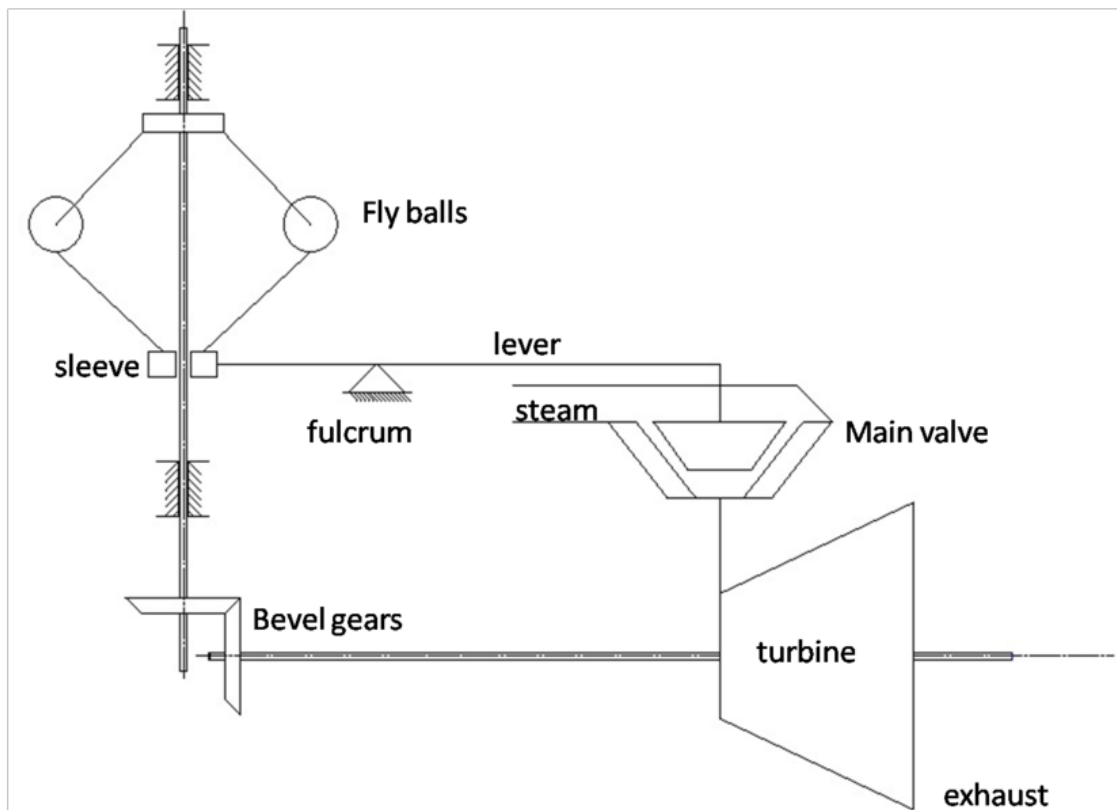

By-pass Governing:

- This method is used in modern impulse turbine operating at a very high pressure.
- In this method the whole steam enters the nozzle box through a throttle valve. This valve controls the speed of turbine for all load up to economical load. For the loads more than economical load, the by-pass valve opens and allows the steam to pass from the first stage nozzle box into steam belt and so into the fourth stage nozzle. When the load stabilizes, the valve closes.

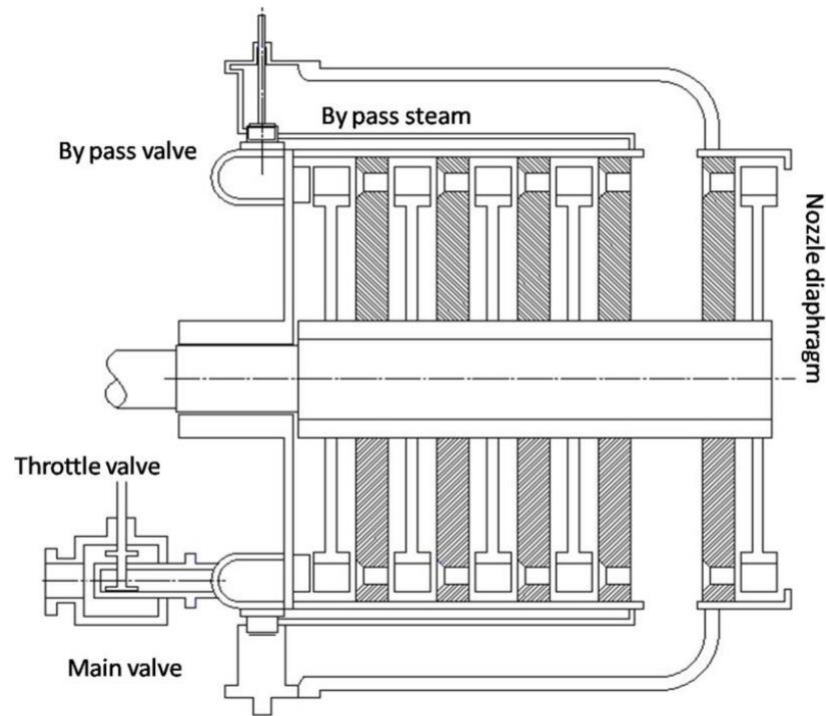

Nozzle Control Governing:

- It is basically used for part load condition.

- In this method, some set of nozzles are grouped together and steam flow to each group of the nozzle is controlled by valves. Actually, nozzle control governing is restricted to the first stage of turbine whereas the subsequent nozzle area in other stage remains constant.
- In this governing rate of steam flow is depending on the opening and closing of set of nozzles rather than regulating its pressure.

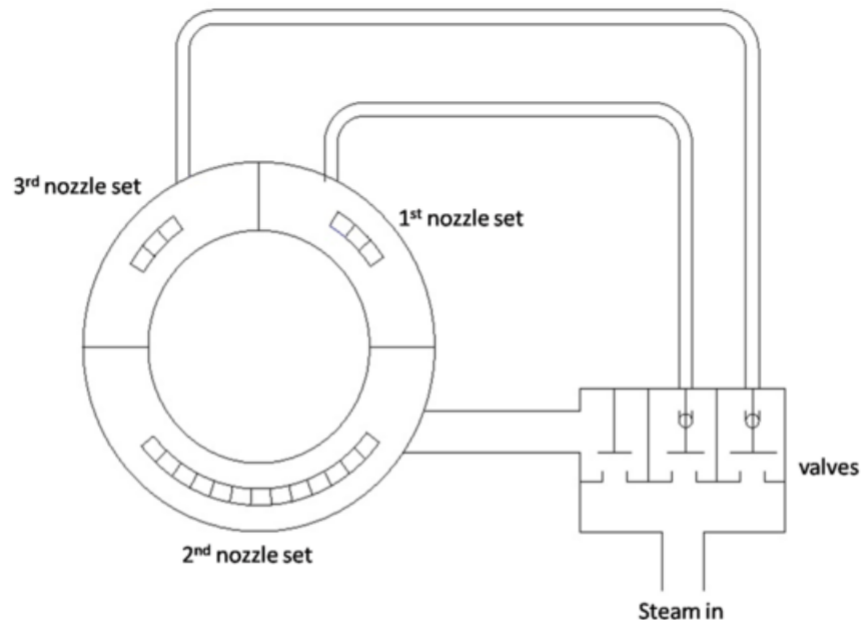

Performance of steam turbine:

Blade efficiency or Diagram efficiency:

It is the ratio of the work done on the blades per kg of steam to the energy supplied to the blades per kg of steam.

Mathematically: Blade efficiency (η_b) = $\frac{W}{\Delta h} \times 100 = \frac{2u(V_1 \cos \alpha - u)}{V_1^2 - V_2^2} \times 100$

Stage efficiency:

It is the ratio of the work done on the blade in heat unit to the total heat energy supplied per stage.

If Δh is the total heat energy drop in the nozzle ring, then the total energy supplied per stage is Δh .

Mathematically: Stage efficiency (η_s) = $\frac{W}{\Delta h} \times 100 = \frac{2u(V_1 \cos \alpha - u)}{\Delta h} \times 100$

Nozzle efficiency:

It is the ratio between actual heat drop of steam in the nozzle and adiabatic or isentropic heat drop of steam in the nozzle.

Mathematically: Nozzle efficiency (η_n) = $\frac{h_1 - h_2}{h_1 - h_2^*}$

Relation between efficiencies:

Stage efficiency (η_s) = Blade efficiency (η_b) \times Nozzle efficiency (η_n)

Steam Condenser:

- A steam condenser is a closed vessel into which the steam is exhausted, and condensed after doing work in the turbine. A steam condenser has the following two objectives.
- The main object of condenser is to maintain a low pressure (below atmospheric pressure) so as to draw the maximum possible energy from steam. So, the efficiency of plant can be increased.
- It is used to supply pure feed water to the hot well, from where it is pumped back to the boiler.

Classification of Condensers:

The steam condensers may be broadly classified into the following types:

- Jet condensers or mixing type condensers
 - Parallel flow jet condenser
 - Counterflow or low-level jet condenser
 - Barometric or high-level jet condenser, and
 - Ejector condenser
- Surface condensers or non-mixing type condensers.
 - Down flow surface condenser
 - Central flow surface condenser
 - Regenerative surface condenser
 - Evaporative condenser.

Elements of Steam Condensing Plant:

A steam condensing plant consists of the following elements.

▪ Condenser

- A condenser is the heat exchanger in which heat exchange occurs between the hot exhaust steam of turbine and cold water. It works at a low pressure.

▪ Air Extraction Pump

- It is used to maintain the vacuum pressure inside of the condenser.

▪ Condensate Extraction Pump

- It is a low-pressure pump which is used to remove the condensed from the condenser and to supply it into the hot well.

▪ Cooling Water Circulating Pump

- It is used to circulate the cooling water from cooling tower to condenser.

▪ Hot Well

- It is a tank which stores the condensate which comes from the condenser.

▪ Cooling Tower

- It is a heat exchanger in which hot water extracted from the condenser transfers heat to the cold atmospheric air and gets converted into cold water. This cold water is supplied into the condenser by cooling water pump to remove heat from steam. Some amount of water gets vaporized in the cooling tower.

▪ Boiler Feed Pump

- It is a pump which is used to supply the water from hot well to the boiler.

▪ Makeup Water Pump

- When there is deficiency of cooling water, makeup water needs to be added by the help of the makeup water pump to deliver fresh water from a sump to the condensing plant.

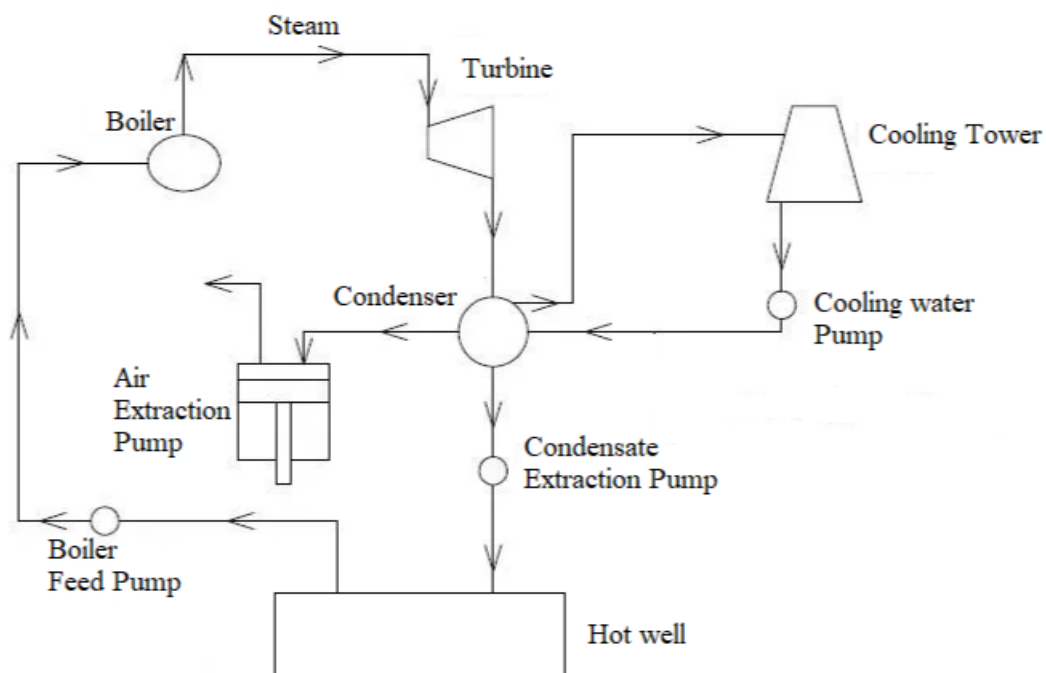

Cooling Tower:

- Cooling tower is used to reject heat into the atmosphere.
- The cold water exits from the cooling tower is sent into the condenser. This water is converted into hot water after receiving heat from the steam inside the condenser. Hot water is extracted from the condenser and supplied to the cooling tower where it is cooled by the atmospheric air.

Types of cooling tower:

Cooling towers can be classified on the basis of method of air circulation. Such as:

- Natural draught cooling tower
- Mechanical draught cooling tower
 - Forced draught cooling tower
 - Induced draught cooling tower

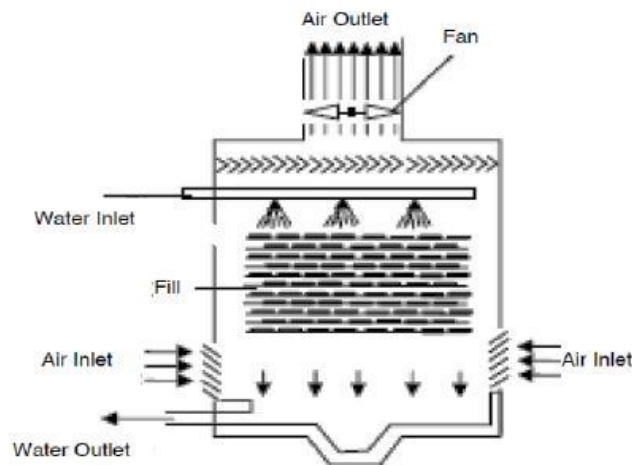

Spray pond:

- A spray pond is a reservoir in which warmed water is cooled before reuse by spraying the warm water with nozzles into the cooler air.
- In spray type cooling method, a large surface of water is exposed for evaporation.
- The hot water extracted from the condenser is supplied to the surface of the cooling tank and is projected into thin horizontal sheets. Nozzles are fitted on the sheets. These nozzles brake up the water into drops. Water droplets gets cooled due to conduction and convection. Cold water is collected at the bottom of the tank.

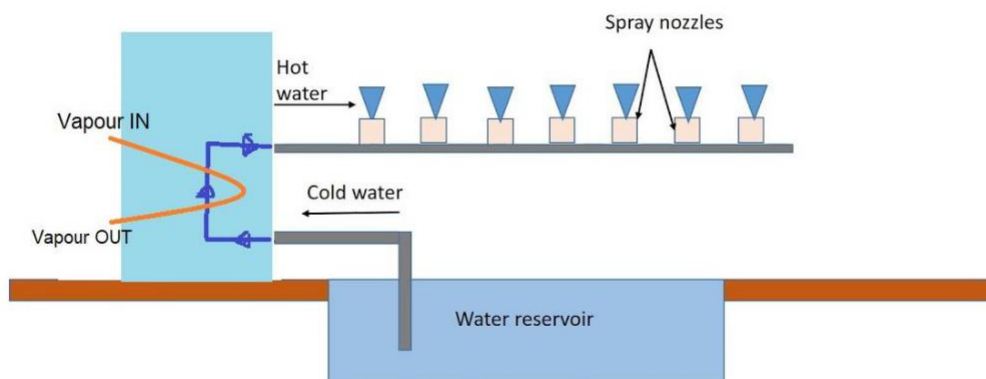

List of thermal power plants in Odisha:

Sl.No.	Name of the Plant	Capacity in MW
1.	Jindal Steel and Power Ltd	810
2.	NALCO Ltd., Captive Power Plant	1200
3.	GMR Energy	1050
4.	Vedanta Ltd., IPP and CPP	2400 and 1215
5.	Talcher Super Thermal Power Station	3000
6.	Jindal India Thermal Power Ltd	1200
7.	Rourkela Steel Plant (CPP-I)	100
8.	Thermal Power Station (OPGC	420
9.	HINDALCO Industries Ltd (CPP),	467
10.	TATA Bhushan Power & Steel Ltd.	370

Site Selection for thermal power plants:

The following points should be taken into consideration while selecting the site for a steam power station.

- Availability of raw material
- Nature of land
- Cost of land
- Availability of water
- Transport facilities
- Ash disposal facilities
- Availability of labour
- Size of the plant
- Load centre
- Public problem
- Future extension